

Australian/New Zealand Standard™

Structural steel

Part 1: Hot-rolled bars and sections

Originated in Australia as part of AS A1—1925.
Originated in New Zealand as AS/NZS 3679.1:1996.
Previous edition 2010.
Fourth edition 2016.

COPYRIGHT

© Standards Australia Limited/Standards New Zealand

All rights are reserved. No part of this work may be reproduced or copied in any form or by any means, electronic or mechanical, including photocopying, without the written permission of the publisher, unless otherwise permitted under the Copyright Act 1968 (Australia) or the Copyright Act 1994 (New Zealand).

Jointly published by SAI Global Limited under licence from Standards Australia Limited, GPO Box 476, Sydney, NSW 2001 and by Standards New Zealand, PO Box 10729, Wellington 6011.

ISBN 978 1 76035 434 3

PREFACE

This Standard was prepared by the Joint Standards Australia/Standards New Zealand Committee BD-023, Structural Steel, to supersede AS/NZS 3679.1:2010.

The objective of this Standard is to specify requirements for manufacturers and suppliers of hot-rolled structural steel bars and sections for general structural and engineering applications.

This edition includes the following major changes from the previous edition:

- (a) Requirements for type testing, and minimum production testing and inspections, have been included in the normative appendix on product conformity.
- (b) Test certificates are required to be available for all products produced to this Standard.
- (c) Labelling requirements have been added to enable products compliant with this Standard to be traceable back to its corresponding test certificate.
- (d) The prescriptive requirement of a rolled in mark on hot rolled sections greater than 150 mm has been replaced by a performance based requirement that provides the same level of permanency in identification.
- (e) Definitions, clause numbering and layout across the four steel product Standards AS/NZS 1163, AS/NZS 3678, AS/NZS 3679.1 and AS/NZS 3679.2 are consistent wherever practicable.

A statement expressed in mandatory terms in a note to a table is deemed to be a requirement of this Standard.

The terms 'normative' and 'informative' have been used in this Standard to define the application of the appendix to which they apply. A 'normative' appendix is an integral part of a Standard, whereas an 'informative' appendix is only for information and guidance.

CONTENTS

	<i>Page</i>
1 SCOPE.....	4
2 NORMATIVE REFERENCES	4
3 DEFINITIONS.....	5
4 DESIGNATION.....	7
5 MANUFACTURING PROCESS—STEEL FEED	7
6 CHEMICAL COMPOSITION	7
7 MANUFACTURING TOLERANCES.....	9
8 FREEDOM FROM DEFECTS.....	21
9 TESTING.....	22
10 MECHANICAL PROPERTIES	26
11 IDENTIFICATION, TEST AND INSPECTION CERTIFICATES.....	28
12 SAMPLING AND TESTING TO DEMONSTRATE PRODUCT CONFORMITY ..	30
13 ROUNDING OF NUMBERS.....	30
14 MANIPULATION	30
15 SECTION DESIGNATIONS, DIMENSIONS AND MASSES.....	30
 APPENDICES	
A PURCHASING GUIDELINES	31
B PRODUCT CONFORMITY	33
C COLD-BENDING OF ROUNDS, FLATS AND SQUARES DURING FABRICATION.....	39
D SECTION DESIGNATIONS DIMENSIONS AND MASSES.....	40
E MEASUREMENT OF CAMBER AND SWEEP IN UNIVERSAL SECTIONS	48
F STEEL FOR SEISMIC AND FRACTURE CRITICAL APPLICATIONS (NEW ZEALAND ONLY)	49
 BIBLIOGRAPHY.....	 50

STANDARDS AUSTRALIA/STANDARDS NEW ZEALAND

Australian/New Zealand Standard
Structural steel

Part 1: Hot-rolled bars and sections

1 SCOPE

This Standard specifies the requirements for the production and supply of hot-rolled structural steel bars and sections.

This Standard is intended for general structural and engineering applications. All grades specified in this Standard are suitable for—

- (a) welding in accordance with AS/NZS 1554, Parts 1, 2, 5 and 7; and
- (b) fastening, as specified in AS 3990, AS 4100, AS/NZS 4600, AS 5100.6 and NZS 3404.

This Standard does not cover the following:

- (i) Structural steel—welded I sections.
- (ii) Carbon steels and carbon-manganese steels—Hot-rolled bars and semi-finished products.
- (iii) Steel reinforcing bars for concrete.

Requirements for product conformity to this Standard are given in Appendix B.

NOTES:

- 1 Guidelines for purchasers on requirements that should be specified by the purchaser and those that should or may be agreed on at the time of enquiry and order are given in Appendix A.
- 2 Guidelines on cold-bending of rounds, flats and squares during fabrication are given in Appendix C.

2 NORMATIVE REFERENCES

The following normative documents are referenced in this Standard:

NOTE: Documents referenced for informative purposes are listed in the Bibliography.

AS

1391	Metallic materials—Tensile testing at ambient temperature
1544	Methods for impact tests on metals
1544.2	Part 2: Charpy V-notch
2706	Numerical values—Rounding and interpretation of limiting values
3990	Mechanical equipment—Steelwork
4100	Steel structures
5100	Bridge design
5100.6	Part 6: Steel and composite construction

AS/NZS

1050	Methods for the analysis of iron and steel (series)
1050.1	Part 1: Sampling iron and steel for chemical analysis

AS/NZS	
1554	Structural steel welding
1554.1	Part 1: Welding of steel structures
1554.2	Part 2: Stud welding (steel studs to steel)
1554.5	Part 5: Welding of steel structures subject to high levels of fatigue loading
1554.7	Part 7: Welding of sheet steel structures
4600	Cold-formed steel structures
ISO	
2566	Steel—Conversion of elongation values
2566-1	Part 1: Carbon and low alloy steels
7870	Control charts
7870-3	Part 3: Acceptance control charts
14284	Steel and iron—Sampling and preparation of samples for the determination of chemical composition
NZS	
3404	Steel Structures Standard
3404.1	Part 1: Materials, fabrication, and construction

3 DEFINITIONS

For the purpose of this Standard, the definitions below apply.

3.1 Analysis

3.1.1 *Cast analysis*

Chemical analysis determined from test samples taken from the ladle, tundish or mould during casting.

3.1.2 *Product analysis*

Chemical analysis determined from a test sample of the finished product.

3.2 Bars

Finished products of solid section, which may be flats, hexagons, rounds or squares.

3.3 Batch

A group of rolled sections or bars consisting of finished steel of the same yield stress gradation (see Tables 14 and 15) and product form, treated in the same manner and from the same heat.

3.4 Can

To denote a capability or possibility that is available or that might occur.

3.5 Crack

Narrow line of fracture on the surface.

3.6 Defects

Surface discontinuities, including cracks, laps and seams, with a depth or area, or both, greater than a specified limiting value.

3.7 Factory production control

Operational techniques and all measures necessary to regulate and maintain the conformity of the product to the requirements of the relevant product standard.

3.8 Heat

A product of a ladle of steel melted in one vessel and processed under the same conditions.

3.9 Imperfections

Surface discontinuities including cracks, laps and seams, with a depth or area, or both, less than or equal to a specified limiting value.

3.10 Inspection

Judgment by competent personnel to determine acceptability against requirements.

3.11 Lap

Overlapping material partially connected with the base material.

3.12 Longitudinal direction

Direction of the greatest extension of the steel during rolling.

3.13 Manufacturer

The business operating the hot rolling process producing the finished steel product.

3.14 May

Indicates the existence of an option.

3.15 Primary rolled product

Steel product produced in a primary mill by the direct hot-rolling of an ingot or from a continuously cast bloom.

3.16 Purchaser

Organization or person who is a recipient from a supplier of a steel product manufactured to this Standard.

3.17 Seams

Caused when imperfections in the semi-finished product are elongated and extended during rolling.

3.18 Sections

Rolled finished sections of special contour and dimensions (see Appendix D).

3.19 Shall

Indicates that a statement is mandatory.

3.20 Should

Indicates a recommendation.

3.21 Supplier

An organization or person that provides steel products manufactured to this Standard.

3.22 Testing

Chemical analysis tests and mechanical tests undertaken by an accredited laboratory as required by this Standard.

3.23 Test piece

Piece prepared for testing, made from a test specimen by a mechanical operation.

3.24 Test sample

Portion of material or product, or a group of items selected from a test batch or group by a sampling procedure.

3.25 Test specimen

Portion or a single item taken from the test sample for the purpose of eventually applying a particular test.

3.26 Transverse direction

Direction at right angles to the direction of the greatest extension of the steel during rolling.

3.27 Type testing

Testing performed to prove that the material is capable of conforming to the requirements of this Standard.

4 DESIGNATION

All grades shall be designated in the format shown in the following examples:

Examples: AS/NZS 3679.1-350
AS/NZS 3679.1-350L0
AS/NZS 3679.1-300S0

where

AS/NZS 3679.1 = number of this Standard

350 = nominal minimum yield stress of the steel, in MPa, (see Tables 14 and 15)

L = guaranteed impact properties of the material (when applicable)

S = guaranteed seismic impact properties of the material (when applicable)

0 = low temperature impact test at 0°C (when applicable)

5 MANUFACTURING PROCESS—STEEL FEED

The steel shall be made by either the basic oxygen process or an electric arc process.

6 CHEMICAL COMPOSITION

6.1 General

The method of sampling for chemical analysis shall be in accordance with AS/NZS 1050.1 or ISO 14284. Chemical composition shall be determined in accordance with AS/NZS 1050 series Standards, or other procedures that achieve the same or better degree of accuracy.

6.2 Cast analysis

A cast analysis of the steel shall be made from each heat to determine the proportions of the specified elements. In cases where it is impracticable to obtain samples from liquid steel, analysis on test samples taken in accordance with AS/NZS 1050.1 or ISO 14284 may be reported as cast analysis.

The cast analysis of the steel shall conform to the limits given in Table 1 for the appropriate grade.

TABLE 1
CHEMICAL COMPOSITION OF BARS AND SECTIONS

Grade (see Note 1)	Cast analysis (max.) (see Notes 2 and 3)						
	%						
	C	Si	Mn	P	S	Micro-alloying elements (see Note 4)	CE (see Note 5)
300, 300L0, 300L15 and 300S0	0.25	0.50	1.60	0.040	0.040	(See Note 6)	0.44
350, 350L0, 350L15 and 350S0	0.22	0.50	1.60	0.040	0.040	(See Note 7)	0.45

NOTES:

- 1 The use of sulphide modification steel-making techniques for these grades is permitted.
- 2 Grain refining elements, i.e. aluminium and titanium may be added, provided that the total content does not exceed 0.15%. Limits are for total or soluble aluminium.
- 3 The following elements may be present to the limits stated, subject to a maximum total of 1.00%:
 - (a) Copper: 0.50%.
 - (b) Nickel: 0.50%.
 - (c) Chromium: 0.30%.
 - (d) Molybdenum: 0.10%.
- 4 For grades, 300, 300L0 and 300S0, the following are not considered as micro-alloying elements:
 - (a) Titanium: 0.040% maximum.
 - (b) Niobium: 0.020% maximum.
 - (c) Vanadium: 0.030% maximum.
 - (d) Niobium plus vanadium: 0.030% maximum.
- 5 Carbon equivalent (CE) is calculated from the following equation:

$$CE = C + \frac{Mn}{6} + \frac{Cr + Mo + V}{5} + \frac{Ni + Cu}{15}$$
- 6 Micro-alloying elements are not permitted in grades 300 and 300S0 except in thicknesses greater than or equal to 15 mm, where the following apply:
 - (a) The maximum combined micro-alloying element content is 0.15%.
 - (b) Where micro-alloying elements are used, the percentage of each element shall be shown on the certificates.
- 7 For grades 350, 350L0 and 350S0 micro-alloying elements niobium, vanadium and titanium may be added, provided that their total combined content does not exceed 0.15%.
- 8 Boron shall not be intentionally added to the steel without the agreement of the purchaser.

6.3 Product analysis

Chemical analysis of the finished product is not a requirement of this Standard. If the steel is subjected to a product analysis, the chemical composition shall conform to the limits given in Table 1 with the tolerances given in Table 2.

TABLE 2
PRODUCT ANALYSIS TOLERANCES
FOR GRADES GIVEN IN TABLE 1

Element	Tolerance over maximum limit, %
Carbon	0.04
Silicon	0.05
Manganese	0.10
Phosphorus	0.01
Sulfur	0.01

6.4 Residual elements

Elements not given in Table 1 for the relevant grade shall not be intentionally added to steel without the agreement of the purchaser.

7 MANUFACTURING TOLERANCES

7.1 Bars

Variations from nominal dimensions of a bar shall not exceed the limits given in Tables 3 to 7 and Figures 1 and 2, as appropriate.

Permissible variations in straightness for bars and light angles having a combined leg length of 150 mm or less shall not exceed—

$$\frac{\text{Length}}{250}$$

NOTE: This permissible variation does not apply if any heating operation has been performed subsequent to rolling.

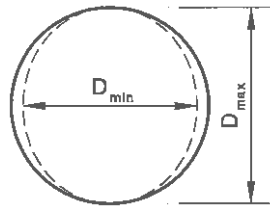

$$\text{Out-of-round} = D_{\max} - D_{\min}$$

(a)

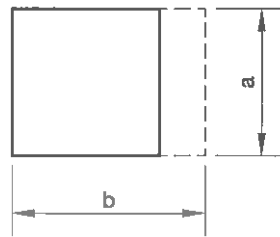

$$\text{Out-of-square} = |a - b|$$

(b)

DIMENSIONS IN MILLIMETRES

FIGURE 1 MEASUREMENTS FOR OUT-OF-ROUND AND OUT-OF-SQUARE

TABLE 3
PERMISSIBLE VARIATIONS IN CROSS-SECTIONAL
DIMENSIONS FOR ROUNDS AND SQUARES

Specified size (diameter or thickness)		millimetres		
		Permissible variation from specified size		Permissible out-of-round or out-of-square
≤25		+0.25	-0.25	0.40
>25	≤30	+0.30	-0.30	0.45
>30	≤40	+0.40	-0.40	0.60
>40	≤50	+0.50	-0.50	0.75
>50	≤60	+0.60	-0.60	0.90
>60	≤70	+0.70	-0.70	1.05
>70	≤80	+0.80	-0.80	1.20
>80	≤100	+0.90	-0.90	1.35
(see Note)				
>100	≤125	+3.20	-0	3.20
>125	≤170	+4.80	-0	4.80
>170	≤215	+6.40	-0	6.40

NOTE: For material produced as primary-rolled product (see Clause 3.15), optional dimensional tolerances in the size range >80, ≤100 are +2.45, -0, and the permissible out-of-round or out-of-square is 1.85.

TABLE 4
WIDTH TOLERANCES FOR FLATS

Specified width		Width tolerance	
≤25		+0.40	-0.40
>25	≤50	+0.80	-0.80
>50	≤100	+1.60	-0.80
>100	≤150	+2.40,	-1.60
>150	≤200	+3.20,	-3.20
>200	≤300	+3.20,	-3.20

TABLE 5
THICKNESS TOLERANCES FOR FLATS

Specified width	Thickness tolerance (plus or minus)				
	Specified thickness				
	<6	≥6 ≤12	>12 ≤25	>25 ≤50	>50
≤25	0.20	0.20	0.25	—	—
>25 ≤50	0.20	0.30	0.40	0.80	—
>50 ≤100	0.20	0.40	0.50	0.80	1.20
>100 ≤150	0.25	0.40	0.50	0.80	1.60
>150 ≤200	0.25	0.40	0.50	0.80	—
>200 ≤300	—	0.40	0.50	0.80	—

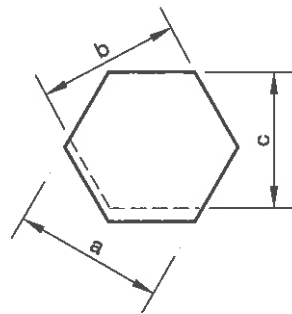

$$\text{Out-of-hexagon} = \max(|a-b|, |a-c|, |b-c|)$$

DIMENSIONS IN MILLIMETRES

FIGURE 2 MEASUREMENTS FOR OUT-OF-HEXAGON

TABLE 6
PERMISSIBLE VARIATIONS IN
CROSS-SECTIONAL DIMENSIONS FOR HEXAGONS

			millimetres	
Specified thickness		Permissible variation from specified thickness		Permissible out-of-hexagon
≤12		+0.20	-0.20	0.30
>12	≤25	+0.25	-0.25	0.40
>25	≤40	+0.55	-0.35	0.60
>40	≤50	+0.80	-0.40	0.90
>50	≤65	+1.20	-0.40	1.10

TABLE 7
PERMISSIBLE VARIATIONS IN
LENGTH FOR BARS AND SECTIONS

Specified length m		Permissible variation from specified length mm	
≤7		+50	-0
>7	≤12	+75	-0
>12		+100	-0

NOTE: Universal sections are normally supplied to a tolerance of +150 mm, -0 mm.

7.2 Sections

Variations from nominal dimensions of a section shall not exceed the appropriate limits given in Tables 7 to 11 and Figures 3 to 7, as appropriate. The mass per unit length as measured on a sample shall be not less than 97.5% of the nominal value. The mass of any group of lengths of section shall be within 2.5% of the nominal value.

For the purpose of this Clause, a group of lengths shall consist of sections of the same nominal dimensions, having—

- (a) minimum mass of 1 tonne; and
- (b) minimum number of 10 lengths.

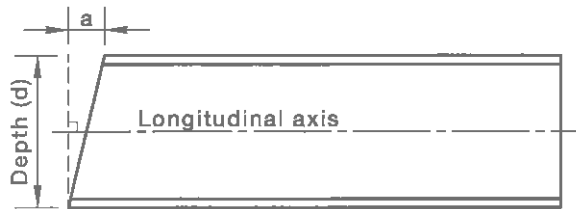

Off-square = a

Section	Permissible off-square for end cuts of sections 'a' mm
Channels and tapered-flange beams	0.030 per mm of depth (d) (see Note 1)
Angles	0.030 per mm of leg length (see Note 2)

NOTES:

- 1 See Figures D3, D4, D5 or D6, as appropriate.
- 2 For unequal angles, the off-square is determined on the longer leg.

FIGURE 3 PERMISSIBLE OFF-SQUARE FOR END CUTS OF SECTIONS OTHER THAN UNIVERSAL SECTIONS

TABLE 8
PERMISSIBLE VARIATIONS IN STRAIGHTNESS FOR SECTIONS OTHER THAN UNIVERSAL SECTIONS

Characteristic (see Note 1)	Permissible variation mm
Camber (see Note 2)	$\frac{\text{Length}}{500}$
Sweep	Owing to the extreme variations in flexibility of tapered-flange beams and channels about the y axis, straightness tolerances are as specified by the purchaser for the individual sections involved.

NOTES:

- 1 Measuring of camber and sweep in universal sections shall be in accordance with Appendix E.
- 2 For angles having a combined leg length of greater than 150 mm, this is the straightness tolerance.

TABLE 9
PERMISSIBLE VARIATIONS IN STRAIGHTNESS
FOR UNIVERSAL SECTIONS

millimetres		
Nominal size	Sweep	Camber
Sections with a flange width (b_f) less than 150 mm	$\frac{\text{Length}}{500}$	$\frac{\text{Length}}{1000}$
Sections with a flange width (b_f) equal to the depth (d):	$\frac{\text{Length}}{1000}$ but not more than 10 mm	
(a) Lengths of 14 m and less		
(b) Lengths greater than 14 m	$10 \text{ mm} + \frac{\text{Length} - 14\,000}{1000}$	
All other sections	$\frac{\text{Length}}{1000}$	

NOTE: Owing to the extreme variation in the elastic flexibility of universal sections about the y axis, difficulty may be experienced in obtaining reproducible sweep measurements. Measuring of sweep shall be in accordance with Appendix E.

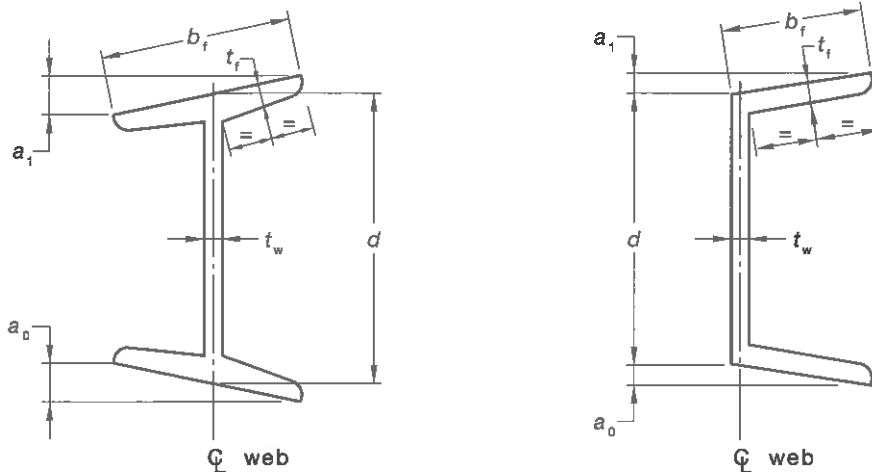

NOTES:

- 1 Dimensions d , a_1 and a_0 are measured parallel with the centre-line of the web. Dimension b_f is measured parallel with the plane of the flange.
- 2 Dimension d is measured at the centre-line of the web for beams and at the back of the web for channels.
- 3 Out-of-square is given by a_1 or a_0 whether the flanges are turned in the same or opposite directions.

1	2	3	4	5	6	7	8			
Section	Depth of section (d)		Flange width (b_f)		Permissible variation in flange or web thickness		Permissible out-of-square on each leg or flange		Permissible out-of-square per mm of nominal flange width b_f	
	Nominal dimension	Permissible variation		Nominal dimension	Permissible variation		(t_f or t_w)		(a_1 or a_0)	($a_1 + a_0$)
		Plus	Minus		Plus	Minus	Plus	Minus		
Tapered-flange beams	$>75 \leq 125$	2.5	1.5	$>40 \leq 80$	3.0	3.0	0.7	0.7	1.5	0.03
				$>80 \leq 90$	3.0	3.0	0.7	0.7	2.0	0.03
Parallel flange channels	$\geq 75 \leq 120$	3.0	1.5	$>35 \leq 55$	3.0	3.0	0.7	0.7	1.0	0.03
	$>120 \leq 360$	3.0	1.5	$>55 \leq 80$	3.0	3.0	1.0	1.0	1.5	0.03
	$>360 \leq 390$	5.0	3.0	$>80 \leq 105$	3.0	4.0	1.0	1.0	2.0	0.03

FIGURE 4 PERMISSIBLE VARIATIONS IN CROSS-SECTIONAL DIMENSIONS FOR TAPERED-FLANGE BEAMS AND PARALLEL FLANGE CHANNELS

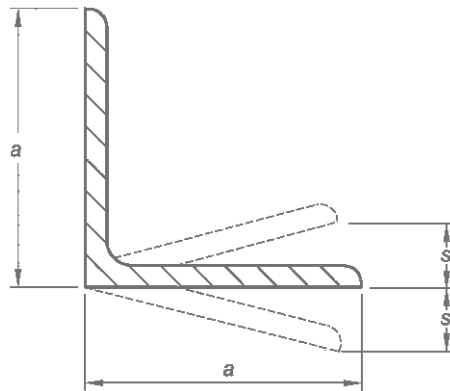

NOTES:

- 1 When measuring the out-of-square, the back of the square and the centre-line of the reference leg shall be parallel.
- 2 The nominal size shall be determined as follows:
 - (a) For equal angles—legs length (a).
 - (b) For unequal angles—length of the longer leg.
- 3 For actual thickness, see Tables D5 and D6.

FIGURE 5 PERMISSIBLE OUT-OF-SQUARE FOR ANGLES

TABLE 10
PERMISSIBLE VARIATIONS IN CROSS-SECTIONAL
DIMENSIONS FOR ANGLES—TOLERANCE ON
LEG LENGTH AND OUT-OF-SQUARE

millimetres			
Nominal leg size	Permissible variation		
	Leg length		Out-of-square (s)
	Over	Under	
≤40	2.5	1.5	1
>40 ≤75	2.5	1.5	2
>75 ≤125	3.0	3.0	3
>125 ≤150	3.0	3.0	4
>150	5.0	3.0	5

TABLE 11
PERMISSIBLE VARIATIONS IN
CROSS-SECTIONAL DIMENSIONS
FOR ANGLES—THICKNESS TOLERANCE

millimetres		
Nominal leg size	Permissible variation	
	Over	Under
≤10	+0.5	-0.5
>10 ≤15	+0.7	-0.7
>15 ≤25	+1.0	-1.0
>25	+1.5	-1.5

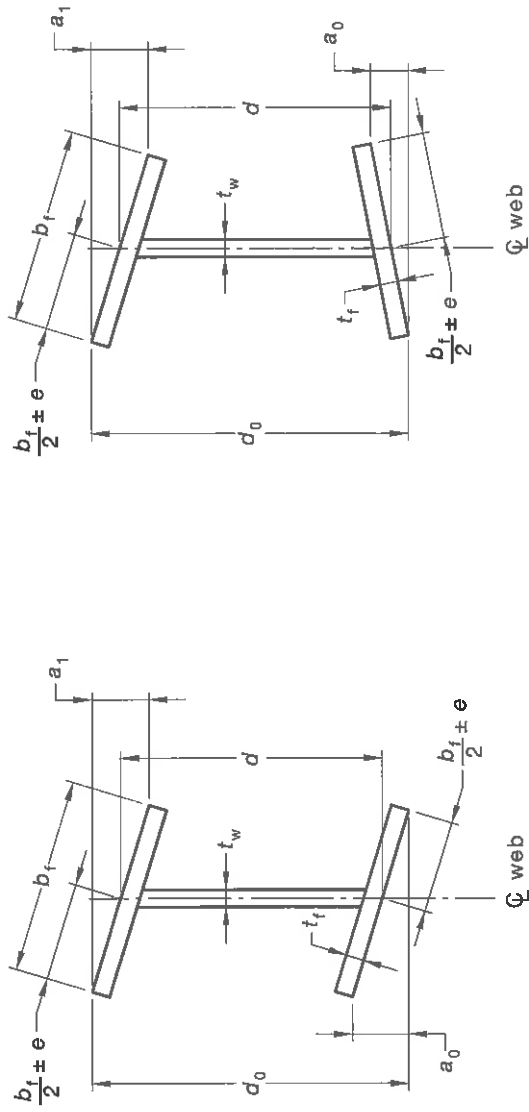

NOTES:

- 1 Dimensions d_0 , d , a_1 and a_0 are measured parallel with the centre-line of the web. Dimensions b_f and $b_f/2 \pm e$ are measured parallel with the plane of the flange.
- 2 Dimension d is measured at the centre-line of the web.

FIGURE 6 (in part) PERMISSIBLE VARIATIONS IN CROSS-SECTIONAL DIMENSIONS FOR UNIVERSAL BEAMS

1	2		3	4	5	6	7	8	9	10	11
	Designation	Nominal mass kg/m									
610 UB	Nominal size mm		Permissible variation of depth (d) mm	Permissible variation of flange width (b _f) mm	Permissible variation of web thickness (t _w) mm	Permissible variation of flange thickness (t _f) mm	Maximum difference of flange over four flanges mm	Permissible out-of-square on each flange (a ₁ or a ₀) mm	Permissible total out- of-square (a ₁ + a ₀) mm	Permissible web off- centre (e) mm	Permissible overall depth over specified depth (d ₀ -d) mm
		125	±3	+6 to -5	±0.7	±1.5	1.5	5	8	5	6
		113	±3	+6 to -5	±0.7	±1.5	1.5	5	8	5	6
		101	±3	+6 to -5	±0.7	±1.0	1.0	5	8	5	6
530 UB		92.4	±3	+6 to -5	±0.7	±1.5	1.5	5	8	5	6
		82.0	±3	+6 to -5	±0.7	±1.0	1.0	5	8	5	6
460 UB		82.1	±3	+6 to -5	±0.7	±1.5	1.5	5	8	5	6
		74.6	±3	+6 to -5	±0.7	±1.0	1.0	5	8	5	6
		67.1	±3	+6 to -5	±0.7	±1.0	1.0	5	8	5	6
410 UB		59.7	±3	+6 to -5	±0.7	±1.0	1.0	5	8	5	6
		53.7	±3	+6 to -5	±0.7	±1.0	1.0	5	8	5	6
360 UB		56.7	±3	+6 to -5	±0.7	±1.0	1.0	5	8	5	6
		50.7	±3	+6 to -5	±0.7	±1.0	1.0	5	8	5	6
		44.7	±3	+6 to -5	±0.7	±1.0	1.0	5	8	5	6
310 UB		46.2	±3	+6 to -5	±0.7	±1.0	1.0	5	8	5	6
		40.4	±3	+6 to -5	±0.7	±1.0	1.0	5	8	5	6
		32.0	±3	+6 to -5	±0.7	±1.0	1.0	5	8	5	6
250 UB		37.3	±3	+6 to -5	±0.7	±1.0	1.0	4	6	5	6
		31.4	±3	+6 to -5	±0.7	±1.0	1.0	4	6	5	6
		25.7	±3	+6 to -5	±0.7	±1.0	1.0	4	6	5	6
200 UB		29.8	±3	+6 to -5	±0.7	±1.0	1.0	4	6	5	6
		25.4	±3	+6 to -5	±0.7	±1.0	1.0	4	6	5	6
		22.3	±3	+6 to -5	±0.7	±1.0	1.0	4	6	5	6
		18.2	±3	+6 to -5	±0.7	±1.0	1.0	4	6	5	6
180 UB		22.2	+2.5 to -1.5	±3	±0.7	±1.0	1.0	2	2.5	2.5	4
		18.1	+2.5 to -1.5	±3	±0.7	±1.0	1.0	2	2.5	2.5	4
		16.1	+2.5 to -1.5	±3	±0.7	±1.0	1.0	2	2.5	2.5	4
150 UB		18.1	+2.5 to -1.5	±3	±0.7	±1.0	1.0	1.5	2.5	2.5	4
		14.0	+2.5 to -1.5	±3	±0.7	±1.0	1.0	1.5	2.5	2.5	4

FIGURE 6 (in part) PERMISSIBLE VARIATIONS IN CROSS-SECTIONAL DIMENSIONS FOR UNIVERSAL BEAMS

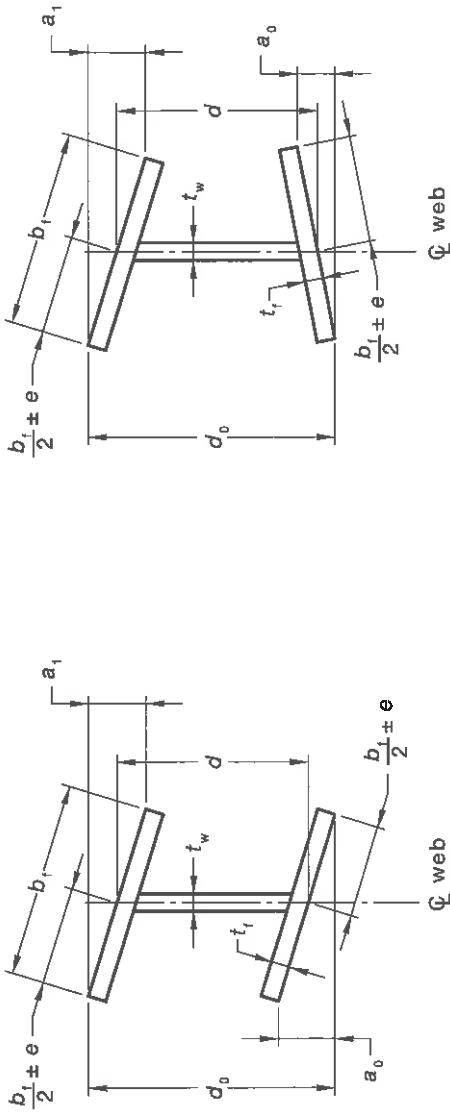

NOTES:

- 1 Dimensions d_0 , d , a_1 and a_0 are measured parallel with the centre-line of the web. Dimensions b_f and $b_f/2 \pm e$ are measured parallel with the plane of the flange.
- 2 Dimensions d is measured at the centre-line of the web.

1	2		3	4	5	6	7	8	9	10	11
	Designation										
Nominal size mm	Nominal mass kg/m	(d)	(b)	(t _w)	(t)	Maximum difference of flange over four flanges	(a ₁ or a ₀)	(a ₁ + a ₀)	(e)	(d ₀ -d)	
310 UC	158	±3	+6 to -5	±1	±1.5	1.5	5	8	5	6	
	137	±3	+6 to -5	±0.7	±1.5	1.5	5	8	5	6	
	118	±3	+6 to -5	±0.7	±1.5	1.5	5	8	5	6	
250 UC	96.8	±3	+6 to -5	±0.7	±1.5	1.5	5	8	5	6	
	89.5	±3	+6 to -5	±0.7	±1.5	1.5	4	6	5	6	
200 UC	72.9	±3	+6 to -5	±0.7	±1.0	1.0	4	6	5	6	
	59.5	±3	+6 to -5	±0.7	±1.0	1.0	4	6	5	6	
150 UC	52.2	±3	+6 to -5	±0.7	±1.0	1.0	4	6	5	6	
	46.2	±3	+6 to -5	±0.7	±1.0	1.0	4	6	5	6	
	37.2	±3	+6 to -5	±0.7	±1.0	1.0	4	6	5	6	
100 UC	30.0	±3	+6 to -5	±0.7	±1.0	1.0	4	6	5	6	
	23.4	±3	+6 to -5	±0.7	±1.0	1.0	4	6	5	6	
	14.8	±3	+6 to -5	±0.7	±1.0	1.0	4	6	5	6	

FIGURE 7 PERMISSIBLE VARIATIONS IN CROSS-SECTIONAL DIMENSIONS FOR UNIVERSAL COLUMNS

8 FREEDOM FROM DEFECTS

8.1 General

The finished steel product shall be free from defects that are detrimental to the materials structural integrity.

Notwithstanding that steel has been accepted previously, if subsequent processing reveals that it contains defects found to be detrimental, the steel shall be deemed not to comply with this Standard.

8.2 Freedom from surface defects

8.2.1 General

The maximum permissible depth of surface imperfections is specified in Clauses 8.2.2 and 8.2.3.

8.2.2 Bars

Imperfections greater than the values listed in Tables 12 and 13 shall be deemed a defect.

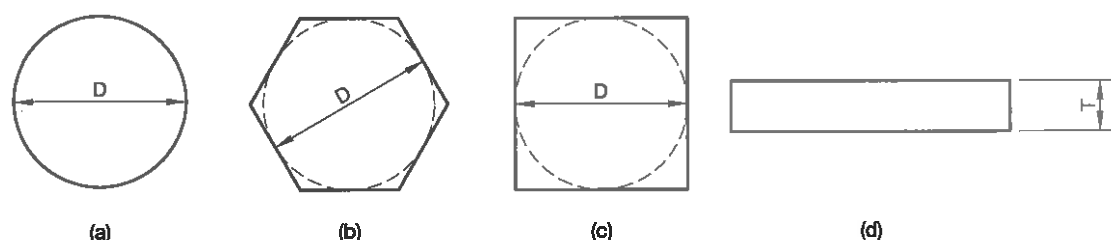

FIGURE 8 PARAMETERS FOR MEASURING PERMISSIBLE IMPERFECTION DEPTH

TABLE 12

PERMISSIBLE SURFACE IMPERFECTION DEPTH

Round hexagonal squares, mm	Maximum imperfection, mm
$D \leq 10$	0.4
$10 < D \leq 42$	$0.04D$
$D > 42$	1.6

NOTE: Refer to Figure 8(a) (b) and (c).

TABLE 13

PERMISSIBLE SURFACE IMPERFECTION DEPTH

Flats, mm	Maximum imperfection, mm
$T \leq 40$	$0.04T$
$T > 40$	1.6

NOTE: Refer to Figure 8(d).

8.2.3 Sections

An imperfection shall be deemed a defect if it exceeds—

- 0.5 mm for material less than 10 mm thick at the point of the imperfections; or
- 7% of the nominal thickness or 3 mm, whichever is the lesser, for material greater than or equal to 10 mm thick at the point of the imperfections, as appropriate.

8.3 Removal of surface defects

8.3.1 Bars

Surface defects shall be removed by machining, grinding, chipping, scarfing or other similar processes. The dimensions remaining after removal of the surface defects shall be in accordance with Clause 7.1.

8.3.2 Sections

The removal of surface defects from a section by grinding, or by chipping followed by grinding and then weld repair, shall comply with the following:

- (a) The area ground shall be well flared without abrupt changes in contour.
- (b) Weld repair surface defect in accordance with Clause 8.4.

8.4 Weld repair of surface defects

8.4.1 General

Weld repair of surface defects from a section, shall comply with the following:

- (a) The total area of the chipped or ground surface of any piece of the section prior to welding shall not exceed 2% of the total surface area of that piece.
- (b) The reduction in thickness of the material resulting from removal of defects at any location shall not exceed the lesser of—
 - (i) 30% of the nominal thickness of the material at the defect; or
 - (ii) 25 mm.
- (c) For the toe of an angle, a beam or a channel, the depth of the chipped or ground depression, measured from the toe inward, shall not exceed the remaining material thickness at the base of the depression.

8.4.2 Welding

Welding used in the repair of surface defects shall utilize a low-hydrogen process in accordance with AS/NZS 1554.1, Category SP.

Welds shall be sound, the weld metal being thoroughly fused without undercutting or overlap. The weld metal shall project at least 1.5 mm above the rolled surface, and the projecting metal shall be removed by grinding, or by chipping followed by grinding, to make it flush with the rolled surface.

9 TESTING

9.1 Selection of test samples

Test samples for the preparation of test pieces for tensile and impact tests shall be taken in accordance with Clause 9.2. Test pieces shall be in the same condition as the finished product. Test samples shall be representative of the body of the product.

NOTE: Where the product is to be further heat-treated and separate heat treatment of test samples is appropriate, this should be specified at the time of enquiry and order (see Appendix A).

9.2 Position and orientation of test pieces

Test samples for the preparation of test pieces for tensile and impact tests shall be taken from the test sample, as shown in Figures 9, 10 and 11, as appropriate.

The test specimens shall be taken with their major axes in the longitudinal direction.

The tensile test piece shall be orientated with the major axis of the test piece in the longitudinal direction.

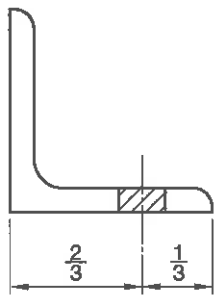

 Position of samples



NOTE: The test sample may be taken from either leg of unequal angles

(a)

(b)

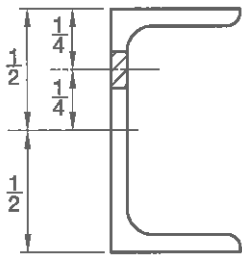

(c)

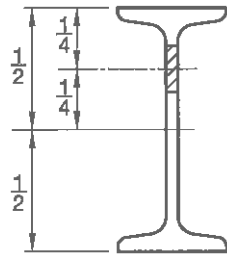

(d)

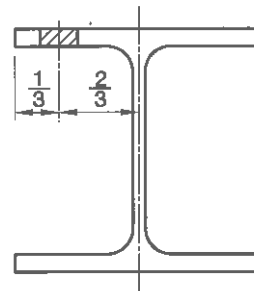

(e)

FIGURE 9 POSITION OF TEST SPECIMENS FOR TENSILE TESTS

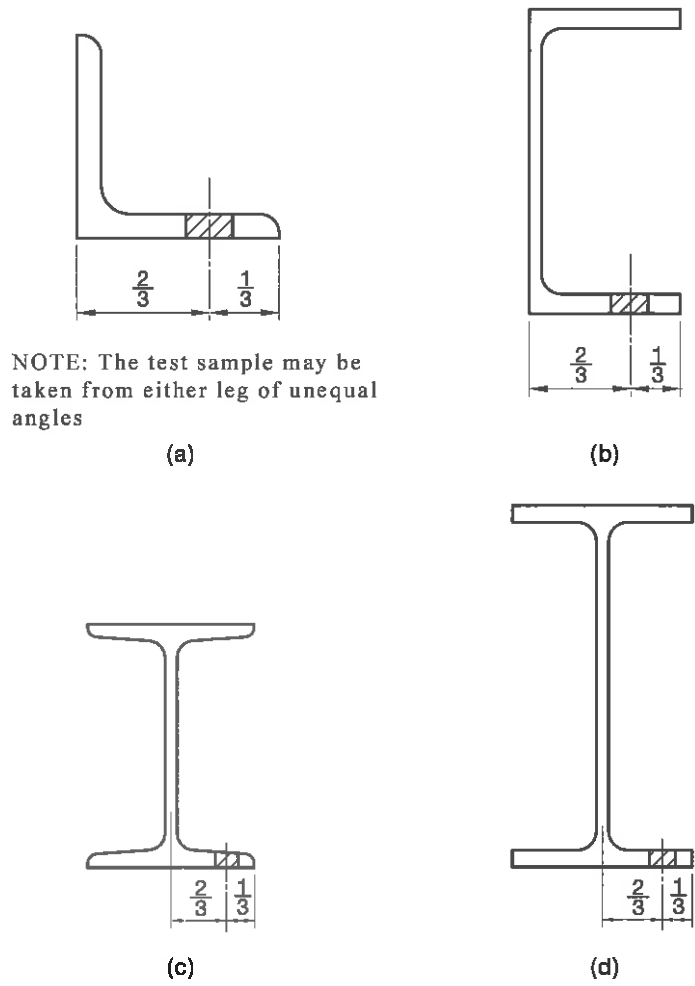

FIGURE 10 POSITION OF TEST SPECIMENS AND TEST PIECE NOTCH LOCATION FOR IMPACT TESTS

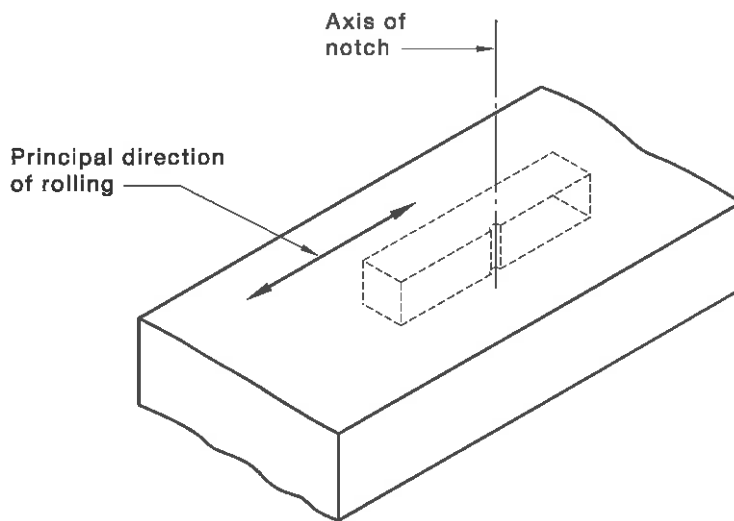

FIGURE 11 ORIENTATION OF IMPACT TEST PIECE

9.3 Preparation of test pieces for mechanical testing

9.3.1 General

Test specimens may be straightened cold before preparation in accordance with this Standard. A test piece which shows defective machining or develops flaws may be discarded and another test specimen may be submitted.

9.3.2 Tensile test piece

9.3.2.1 General

A test piece for tensile testing shall be prepared in accordance with AS 1391.

9.3.2.2 Bars

Bars shall comply with the following:

- (a) Hexagons, rounds and squares with nominal diameter or thickness less than or equal to 30 mm shall be tested in full section.
- (b) For flats with width greater than 40 mm and nominal thickness of less than or equal to 30 mm, the axis of the test piece shall be as near as practicable to the quarter-width position, and shall be tested in full thickness.
- (c) For hexagons, rounds and squares with nominal cross-sectional dimensions greater than 30 mm, a proportional test piece may be used. The axis of the test piece shall be parallel to the rolling direction and as near as practicable to a point one-sixth of the distance between diagonally (or diametrically) opposite surfaces.
- (d) For flats with nominal thickness greater than 30 mm, a proportional test piece may be used. The axis of the test piece shall be parallel to the rolling direction and as near as practicable to the quarter-width position and to a point one-sixth of the distance between opposite surfaces.

9.3.2.3 Sections

For material with thickness greater than 30 mm, either a proportional cylindrical test piece or a non-proportional test piece in accordance with Table C2 of AS 1391—2007 (as amended) shall be used. For material less than or equal to 30 mm in thickness, a non-proportional test piece of full product thickness in accordance with Table C2 of AS 1391—2007 (as amended) shall be used (see Figure 9).

9.3.3 Impact test piece

The axis of the notch shall be perpendicular to the rolled surface of the bar or section other than rounds (see Figures 10 and 11). Test pieces shall be prepared in accordance with AS 1544.2 and with the following, as appropriate:

- (a) *Sections and flat bars* For sections and flat bars of nominal thickness greater than or equal to 20 mm, material within 3 mm from the surface shall not be included. Machine standard test pieces shall be in accordance with Table 16.

For sections and flat bars of nominal thickness less than 20 mm, material within 1 mm from the surface shall not be included. Machine standard test pieces shall be in accordance with Table 16.

NOTE: Impact tests on material with nominal thickness less than 7 mm are not covered by this Standard.

- (b) *Rounds, squares and hexagons* For rounds, squares and hexagons of nominal thickness greater than 50 mm, material within 3 mm from the surface shall not be included. Machine standard test pieces shall be in accordance with Table 16.

For rounds, squares and hexagons of nominal thickness less than or equal to 50 mm, material within 1 mm from the surface shall not be included. Machine standard test pieces shall be in accordance with Table 16.

NOTE: Impact tests on rounds, squares and hexagons with nominal thickness less than 16 mm are not covered by this Standard.

9.4 Mechanical testing

9.4.1 Tensile test

A tensile test shall be made on each test piece prepared from each test sample specified in Clause 9.1.

The tensile test shall be carried out in accordance with AS 1391. The rate of straining when approaching the yield stress shall be within the limits of the conventional straining rate as specified in AS 1391.

Elongation results shall be reported on a gauge length L_0 equal to $5.65\sqrt{S_0}$, where S_0 is the original cross-sectional area of the test piece before testing. Conversion of results from a non-proportional gauge length shall be in accordance with ISO 2566-1.

For test pieces with cross-sectional area greater than 1000 mm², the minimum elongation after conversion to the gauge length of $5.65\sqrt{S_0}$ shall be reduced by 2% from that given in Table 14.

9.4.2 Charpy V-notch impact test

One test in accordance with AS 1544.2 shall be carried out on each of three test pieces prepared from each test sample specified in Clauses 9.1 and 9.2.

10 MECHANICAL PROPERTIES

10.1 Tensile tests

For tensile tests carried out in accordance with Clause 9.4.1, the yield stress, tensile strength and elongation, shall conform to the limits given in Tables 14 and 15, for the appropriate grade.

TABLE 14
TENSILE TEST REQUIREMENTS FOR FLATS AND SECTIONS

Grade	Minimum yield stress, (R_{eH}) MPa (see Note 1)				Minimum tensile strength (R_m) MPa	Minimum elongation on a gauge length of $5.65\sqrt{S_0}$ (see Note 4) %
	Thickness, mm (see Note 3)					
	<11	≥11 and ≤17	>17 and <40	≥40		
300, 300L0	320	300	280	280	440	22
300L15, 300S0	320	300	280	280	440	25 (see Note 2)
350, 350L0	360	340	340	330	480	20
350S0, 350L15	360	340	340	330	480	25 (see Note 2)

NOTES:

- R_{eH} is the upper yield point as determined using AS 1391.
- S0 is the seismic grade. Refer to Appendix F, Paragraph F2, for limitations.
- For a section, the term 'thickness' refers to the nominal thickness of the part from which the sample is taken.
- S_0 is the cross-sectional area of the test piece before testing.
- For flat product, S0 grades are not applicable.

TABLE 15
TENSILE TEST REQUIREMENTS FOR
HEXAGONS, ROUNDS AND SQUARES

Grade	Minimum yield stress, (R_{eH}) MPa (see Note 1)			Minimum tensile strength, (R_m) MPa	Minimum elongation on a gauge length of $5.65\sqrt{S_0}$ (see Note 3) %
	Thickness, mm (see Note 2)				
	≤50	>50 and <100	≥100		
300, 300L0, 300L15	300	290	280	440	22
350, 350L0, 350L15	340	330	320	480	20

NOTES:

- 1 R_{eH} is the upper yield point as determined using AS 1391.
- 2 For a section, the term 'thickness' refers to the nominal thickness of the part from which the sample is taken.
- 3 S_0 is the cross-sectional area of the test piece before testing.
- 4 For flat product, S_0 grades are not applicable.

10.2 Impact test

For impact tests, carried out in accordance with Clause 9.4.2, the absorbed energy values shall conform to the limits given in Table 16.

TABLE 16
CHARPY V-NOTCH IMPACT TEST REQUIREMENTS

Grade	Test temperature	Minimum absorbed energy, J					
		Size of test piece					
	°C	10 mm × 10 mm		10 mm × 7.5 mm		10 mm × 5 mm	
		Average of 3 tests	Individual test	Average of 3 tests	Individual test	Average of 3 tests	Individual test
300L0/350L0	0	27	20	22	16	18	13
300L15/350L15	-15	27	20	22	16	18	13
300S0/350S0 (see Note 1 and 2)	0	70	50				

NOTES:

- 1 S0 is a seismic grade low temperature impact test at 0°C.
- 2 Impact testing for S0 only applies to sections with elements greater than 12 mm thick.

11 IDENTIFICATION, TEST AND INSPECTION CERTIFICATES

11.1 Identification

11.1.1 Individual length markings

All angles with nominal leg lengths not less than 150 mm and other hot rolled sections, not less than 150 mm in depth, shall be clearly and legibly identified with the following requirements:

- (a) A mark with the two characters 'AS' to indicate that it is made to this Australian Standard.
- (b) The manufacturer's name or mark, or both.
- (c) The grade of the steel.
- (d) A mark allowing it to be traced to a test certificate.
- (e) The nominal size and shape.

The markings specified in Items (a) and (b) shall be—

- (i) marked at the time of manufacture;
- (ii) legible after fabrication and coating, such as a rolled-in mark;
- (iii) applied at regular centres no more than 4 m apart; and
- (iv) not detrimental to the use of the section.

The markings specified in Items (c), (d) and (e) shall be—

- (A) produced at the time of manufacture;
- (B) legible and durable to the point of fabrication; and
- (C) not detrimental to the use of the product.

If the identified portion of the product is subsequently removed, then these identifications shall be transferred to each remaining portion of the product.

11.1.2 Bundle/pack markings

The material shall be marked or tagged for bundles with the following:

- (a) The manufacturer's name or mark, or both.
- (b) Reference to this Standard, i.e. AS/NZS 3679.1.
- (c) The grade of steel (see Clause 4).
- (d) The product to be traced to the batch of steel from which it was made.
- (e) The nominal size and shape.

If the identified portion of the product is subsequently removed, then these identifications shall be transferred to each remaining portion of the product.

11.2 Test and inspection certificates

11.2.1 General

A test and inspection certificate shall be available to the purchaser for all products manufactured to this Standard for each batch produced.

11.2.2 *Transmission of test and inspection certificates by an intermediary*

An intermediary shall only pass on either an original or a copy of the inspection documents provided by the manufacturer without any alteration except as noted below. This documentation shall be accompanied by suitable means of identification of the product, in order to ensure the traceability between the product and the documentation.

Copying of the original document is permitted, provided that—

- (a) traceability of product is maintained; and
- (b) the original manufacturer's document is available on request.

When producing copies of the original manufacturer's document, it is permissible to replace the original delivered quantity with the subsequent partial quantity.

NOTE: In the context of this Standard, an intermediary is a supplier and not a manufacturer (see Clauses 3.13 and 3.21 respectively).

11.2.3 *Qualifications on test and inspection certificates*

A test and inspection certificate shall provide the following:

- (a) Tests performed by a laboratory accredited by signatories to International Laboratory Accreditation Corporation (ILAC) through their Mutual Recognition Agreement (MRA) for the specific tests described in this Standard. The appropriate logo or further details of the ILAC (MRA) signatory shall be noted on the document.

NOTE: In Australia ILAC (MRA) accredited bodies include National Association of Testing Authorities (NATA), and in New Zealand they include International Accreditation New Zealand (IANZ).

- (b) Additional tests as agreed between the purchaser and manufacturer

NOTE: See Appendix A.

11.2.4 *Minimum requirements for test and inspection certificates*

All test and inspection certificates shall be in English alphanumeric characters, issued by the manufacturer, and have the following:

- (a) Manufacturer's name.
- (b) The test certificate number.
- (c) The date of certification.
- (d) Product, testing specification and grade, for example AS/NZS 3679.1-350 Grade (see Clause 4).
- (e) Product designation (see Appendix D).
- (f) Product steelmaking process, for example basic oxygen or electric arc.
- (g) Length, bundle, pack or unique identifier to which the test certificate applies [see Clauses 11.1.1(d) and 11.1.2(d)].
- (h) Heat number (from casting).
- (i) Chemical analysis type, for example cast analysis 'L' or product 'P' (see Clauses 6.2 and 6.3).
- (j) For each test, a laboratory identification providing traceability to the laboratory accreditation of the test type.
- (k) A chemical composition of carbon (C), phosphorus (P), manganese (Mn), silicon (Si), sulphur (S), chromium (Cr), molybdenum (Mo), vanadium (V), nickel (Ni), copper (Cu), aluminium (Al), titanium (Ti), niobium (Nb), boron (B) carbon equivalent (CE) and any element intentionally added (see Clauses 6.1, 6.2, 6.3 and 6.4).

- (l) Where relevant, mechanical information as noted below:
 - (i) Tensile tests—yield stress, in MPa, tensile strength, in MPa, and % elongation (see Clauses 9.4.1 and 10.1).
 - (ii) Impact test results at the specified test temperature for low temperature and seismic grades (L0 and S0 Grades, see Clauses 9.4.2 and 10.2).
- (m) The manufacturing facility's quality management system's certifier and certification number.
- (n) The body assessing the product conformity to this Standard. For self-assessment this is the manufacturer; the default scheme is this Standard.
- (o) A declaration from the manufacturer that the products supplied comply with the requirements of this Standard (refer to Clause 12) and Items (a) to (n) above. This shall be validated by the manufacturer's authorized inspection representative, including their name and position.

If the document has been validated by the purchaser's authorized representative or by an inspector designated by a third party, their name and position shall be on the document.

12 SAMPLING AND TESTING TO DEMONSTRATE PRODUCT CONFORMITY

The minimum sampling and testing procedures shall conform to Appendix B. Additional testing may be agreed between the manufacturer and the purchaser.

13 ROUNDING OF NUMBERS

13.1 General

For the purpose of deciding whether a particular requirement of this Standard is complied with, the determined value, observed or calculated, shall be rounded off in accordance with AS 2706.

The number of significant places retained in the rounded-off value shall be the same as that of the specified value in this Standard.

13.2 Tensile properties

The determined value of tensile strength shall be rounded off to the nearest 10 MPa, and the determined value of yield stress shall be rounded off to the nearest 5 MPa.

14 MANIPULATION

Appendix C provides guidance on cold-bending of rounds, flats and squares during fabrication.

15 SECTION DESIGNATIONS, DIMENSIONS AND MASSES

Appendix D provides information on section designations, nominal section dimensions and masses for common hot rolled sections.

APPENDIX A
PURCHASING GUIDELINES
(Informative)

A1 GENERAL

Australian/New Zealand Standards are intended to include the technical provisions necessary for the supply of materials referred to in the particular Standard, but do not purport to comprise all the necessary provisions of a contract. The purchaser may specify additional requirements or be given a choice of optional requirements. These are contractual matters to be agreed upon between the purchaser and the manufacturer, or the supplier.

This Appendix contains detailed explanations, advice and recommendations on the information to be supplied by the purchaser at the time of enquiry and order.

The objective of this Appendix is to avoid misunderstandings and to result in the purchaser receiving satisfactory products and services.

A2 INFORMATION TO BE SUPPLIED BY THE PURCHASER

The purchaser should consider and supply the following information at the time of order, after making due reference to the explanation, advice and recommendations contained in this Appendix:

- (a) Quantity and delivery instructions (dates, schedules, delivery point).
- (b) Dimensions of steel, for example section, length, mass per unit length applicable and bundle masses.
- (c) Designation of grade and Standard number (see Clause 4).
- (d) Any limitations in respect of packaging, for example number or sections per pack and packaging materials.
- (e) Whether a test certificate and/or an inspection certificate is required (see Clause 11.2).
- (f) Whether documentation certifying the product conformity requirements (see Appendix B) is required.
- (g) Whether it is the intention of the purchaser to inspect the steel at the manufacturer's works (see Paragraph A4).
- (h) Any information concerning processing or end use that the purchaser considers would assist the manufacturer.
- (i) Whether a product analysis is required and the frequency of analysis (see Clause 6.3).
- (j) Whether special tolerances on dimensions are required.
- (k) Length of sections (including length tolerance type—see Table 7).
- (l) Any exceptions to the Standard and any special or supplementary requirements, for example non-destructive testing inspection (see Paragraph A3).
- (m) If repair by welding is not allowed.
- (n) Zinc coating requirements. As a guide, recommendations for suitable chemistry of steels are provided in AS/NZS 2312.2.

Further information is available from the Galvanizers Association of Australia (GAA) and Galvanizing Association of New Zealand (GANZ).

NOTE: Any special or supplementary requirements of this Standard are subject to agreement between the purchaser and the manufacturer, or the supplier at the time of enquiry and order, and should be stated on the order.

A3 NON-DESTRUCTIVE EXAMINATION

If non-destructive examination is required by the purchaser, the method to be used and the limits of acceptance should be determined at the time of order.

The method should be in accordance with AS 1171 and AS 2062 as appropriate.

A4 INSPECTION

If it is the purchaser's intention to undertake any of the following functions at the manufacturer's works, this should be notified at the time of order and should be accomplished in a manner that will not interfere with the operation of the works. The functions are as follows:

- (a) Inspect the product during manufacture.
- (b) Select and identify the test samples.
- (c) Witness the tests being made.

The manufacturer should provide all reasonable facilities to enable the purchaser to be satisfied that the product complies with this Standard.

APPENDIX B PRODUCT CONFORMITY

(Normative)

B1 SCOPE

This Appendix sets out the means by which product conformity evaluation shall be demonstrated by the manufacturer or supplier, by—

- (a) Initial type testing; and
- (b) Factory production control, including a minimum testing and inspection frequency plan.

Testing and inspection of one or two samples does not provide an acceptable representation of actual variability in a batch of unidentified steel.

NOTE: The result of testing and inspecting such a sample could fall within or outside the standard range by chance, and does not present a valid picture of the characteristics being evaluated.

The product conformity requirements shall enable conformity assessment to be made by a manufacturer or supplier (first party), a user or purchaser (second party), or an independent body (third party), and shall not be dependent on a quality management systems Standard.

NOTE: An example of a quality management system Standard is AS/NZS ISO 9001.

B2 INITIAL TYPE TESTING

B2.1 General

An initial type testing program shall be carried out in accordance with Paragraph B2.2 under the sole responsibility of the manufacturer of the products before they are first placed onto the market.

Such a program shall be carried out in each case for each grade designation with the highest strength and impact properties which a manufacturer places on the market. Additional programs are required for sections with lower strengths and higher impact property requirements. The testing program shall include the thickest section in each of the thickness ranges specified in Tables 14 and 15 of this Standard.

Initial type testing shall be performed on first application of this Standard. Tests previously performed in accordance with the provisions of this Standard (same product, same characteristic(s) test method, sampling procedure, system of attestation of conformity, etc.) may be taken into account.

In addition the initial type testing shall be performed at the beginning of a new method of production, and/or using a new facility or equipment.

B2.2 Minimum sampling and testing plan

The initial type testing and inspection program comprises of routine testing and inspection at a higher frequency to establish the capabilities of the manufacturing process to produce the steel product. Table B1 provides the minimum testing and inspection frequency plan for type testing. The results of all type tests shall conform to the requirements of this Standard.

TABLE B1
MINIMUM SAMPLING AND TESTING FREQUENCY PLAN FOR TYPE TESTS
AND INSPECTIONS

Characteristic	Clause	Requirement	Test method	Frequency
Designation	4	Steel grade designation correct	Visual	Once
Manufacturing process	5	Determine steel making process	Records inspection	Each heat, minimum of 5
Chemical composition	6.2/6.3	Cast/product analysis	AS/NZS 1050	Each heat, minimum of 5
	6.4	Other elements analysis		
Manufacturing tolerances	7.1 and 7.2	Nominal dimensions	Gauging equipment	Minimum of 30 lengths after set-up
	7.1 and 7.2	Straightness	Straight edge, string line or gauges	
	7.2	Mass	Weighing or by calculation	
Freedom from defects	8.1 and 8.2	Free from surface defects	Visual	Minimum of 30 lengths after set-up
Mechanical properties	9 and 10.1	Tensile strength, yield stress and elongation	In accordance with Clauses 9 and 10	6 tests for each heat for minimum of 5 after set-up
	9 and 10.2	Impact strength for impact grades		
Identification	11.1.1	Individual length markings	Visual inspection	30 lengths produced after set-up
	11.1.2	Bundle/pack markings	Visual inspection	Each bundle

NOTE: Set-up is achieved after the manufacturing process is stable.

B3 PRODUCTION TESTING AND INSPECTIONS

B3.1 Minimum batch testing and inspections

The manufacturer shall ensure that all products conform to the minimum frequency requirements of production testing and inspections as defined in Table B2.

TABLE B2

MINIMUM SAMPLING AND TESTING FREQUENCY PLAN FOR PRODUCTION TESTS AND INSPECTIONS

Characteristic	Clause	Requirement	Test method	Frequency
Manufacturing process	5	Determine steel making process	Records inspection	Each heat
Chemical composition	6.2/6.3	Cast/product analysis	AS/NZS 1050	Each heat
	6.4	Other elements analysis		
Manufacturing tolerances	7.1 and 7.2	Nominal dimensions	Gauging equipment	Once each 30 min of rolling time.
	7.1 and 7.2	Straightness	String line and gauges/straight edge	Constant visual, 1 string line measurement of gauging per hour of processing
	7.2	Mass (for sections only)	Weighing equipment <i>or</i>	At least 1 every 30 min of rolling time.
By calculation and weighing			Calculate weight of at least 1 bar every 30 min of rolling time and weighing every 6 h	
Freedom from defects	8.1	Free from defects	Visual inspection	One × 4-sided inspection of one finisher roll revolution per hour of manufacture
Mechanical properties	9 and 10.1	Tensile strength, yield stress and elongation	In accordance with Clauses 9 and 10 <i>or</i> Clause B3.2	1 test for each batch not greater than 50 tonnes, 2 tests for batches greater than 50 tonnes and 4.4 and 4.3 or by statistical sampling
	9 and 10.2	Impact strength for impact grades		
Identification	11.1.1	Manufacturers mark	Visual inspection	1 per hour
	11.1.2	Bundle pack markings	Visual inspection	Every bundle
Test and inspection certificates	11.2	Test and inspection certificates	Visual and records inspection	Every certificate

B3.2 Statistical sampling

Process verification by statistical sampling or alternate methods can be used to demonstrate product conformity where the conditions required by these provisions are met (see also Note 1).

Where it can be demonstrated that the type test (see Note 2) of any group of products (see Note 3) manufactured under the same conditions of steel supplier, steel grade and steel processing are distributed normally, then it shall be permissible to adopt statistical sampling to verify process acceptance for each product in accordance with ISO 7870-3.

For product conformance to this Standard via statistical sampling, the inputs of process acceptance verification, ongoing testing and statistical sampling shall be demonstrated and, where applicable, also maintained. To ensure that the process being assessed is in control (see Note 1), a statistically significant number of samples needs to be obtained within a rationally determined time period that is reflective of typical manufacturing practice. Within a defined group, each type of test sample randomly selected shall not exceed a sampling period of three months.

Additionally, any sample or sampling that indicates a predicted proportion of nonconforming product in excess of an amount considered within the demonstrated statistical sampling method, shall cause the sampling for that combination of size, thickness and grade to revert to batch sampling rules until it can be demonstrated that the conditions of statistical sampling are valid for that combination.

In the event of actual nonconforming test results, the retest provisions of normal batch testing shall also apply.

NOTES:

1 Statistical sampling is a procedure that enables decisions to be made about the quality and conformity of batches of items after inspecting or testing only a portion of those items. This procedure will only be valid if the sampling plan has been determined on a statistical basis and the following are met:

- (a) The sample is drawn randomly from a population of product of known history that enables verification that the product was made from known materials at essentially the same time by essentially the same processes and under essentially the same system of control.
- (b) For each different situation, a suitable sampling plan is defined. A sampling plan for one manufacturer of given capability and product throughput may not be relevant to another manufacturer producing the same items.

In order for statistical sampling to be meaningful to the customer, the manufacturer or supplier needs to demonstrate how the above conditions have been satisfied. Sampling and the establishment of a sampling plan should be carried out in accordance with recognized Standards (e.g. AS 2490, AS 1199, Parts 0 and 1) and methods.

Under this approach, ongoing sampling and testing of product shall be directed primarily at monitoring the process to ensure that product outcomes are acceptable, within characteristic ranges as well as stable and under control (e.g. normally distributed).

- 2 The type test is the measured parameter such as tensile testing, impact testing, etc. These are long term testing plans based on initial testing undertaken to determine overall conformance and other required controls to be put into place (e.g. same steel supply, same manufacturing process) to ensure ongoing compliance.
- 3 To reduce sampling frequencies, a group of products can consist of an aggregation of batch data from a range of products if it can be demonstrated to be normally distributed.

B3.3 Tensile tests

If the batch includes steel of more than one thickness or diameter, a further tensile test should be made for product from each of the thickness ranges specified in Tables 14 and 15. Additional tensile tests shall be made for each variation in thickness or diameter, above or below the thickness or diameter of the first test piece selected as follows:

TABLE B3
TENSILE TEST—ALLOWABLE
THICKNESS VARIATIONS

Nominal thickness mm	Variation mm
≤50	±5
≥50	±25

B3.4 Impact tests

For impact tests, if the batch includes steel of more than one thickness or diameter, a further impact test shall be made for each variation in thickness or diameter.

B4 Factory production control

B4.1 General

The manufacturer shall establish, document and maintain a factory production control (FPC) system to ensure that the products placed on the market conform with the stated performance characteristics. The FPC system shall consist of procedures, regular inspections, tests and/or assessments, and the use of the results to control raw and other incoming material or components, equipment, the production process and the product.

A quality management system covering the requirements of this Standard, shall be considered to satisfy the requirements of FPC.

NOTE: An example of an appropriate quality management system is AS/NZS ISO 9001.

B4.2 Equipment

B4.2.1 Testing

All weighing, measuring and testing equipment shall be calibrated and regularly inspected according to documented procedures, frequencies and criteria.

B4.2.2 Manufacturing

All equipment used in the manufacturing process shall be regularly inspected and maintained to ensure use, wear or failure does not cause inconsistency in the manufacturing process. Inspections and maintenance shall be carried out and recorded in accordance with the manufacturer's written procedures.

B4.3 Raw materials

The specification of all incoming raw materials shall be documented, as shall the inspection scheme for ensuring their conformity. All manufacturing process and steel feed shall comply with the requirements of Clause 5.

B4.4 Product testing and evaluation

The manufacturer shall establish procedures to ensure that the stated values of all the characteristics are maintained. The characteristics and the means of control shall be in accordance with the minimum requirements listed in Table B2.

B5 NONCONFORMING PRODUCTS

B5.1 General

The manufacturer shall have written procedures specifying the processing of nonconforming product.

B5.2 Retests

B5.2.1 Tensile tests

Two test samples at random from the remainder of the test batch shall be taken. If the test pieces from both additional samples comply with Clauses 9.2, 9.3, 9.4.1 and 10.1, the remainder complies with this Standard.

If one of these additional samples fails to comply, the steel of the applicable test batch does not comply with this Standard.

B5.2.2 Impact tests

If the average value of the three impact test results is less than the specified minimum average, or if one value is less than the specified individual test value given in Table 16, then three additional test pieces from the original sample shall be tested in accordance with Clauses 9.2, 9.3, 9.4.2 and 10.2. These results shall be added to those previously obtained and calculate a new average. If the average value of the six tests is not less than the specified minimum average, and not more than one result of the six tests is less than the specified individual test value given in Table 16, then the unit complies with this Standard.

B5.3 Repair

All repaired product shall be inspected and meet the requirements of this Standard.

B6 DOCUMENTATION

The results of all testing programs shall be recorded and such records shall be maintained and be made available for inspection for a period of at least 5 years after the date when that last product to which the test program refers to was delivered. Results for initial type testing shall be maintained for the period of manufacture of the product.

Documentation shall include information to be supplied to the purchaser, plus manufacturing process, physical and mechanical properties, inspection and testing, and test procedures.

APPENDIX C

COLD-BENDING OF ROUNDS, FLATS AND SQUARES DURING FABRICATION

(Informative)

For rounds manufactured in accordance with this Standard, the minimum diameter of former to be used for cold-bending during fabrication should be as given in Table C1.

For flats and squares manufactured in accordance with this Standard, the minimum diameter of former to be used for cold-bending during fabrication should be as given in Table C2.

NOTES:

- 1 Cold-bending is not recommended where product is to be hot-dipped galvanized or where any acid treatment may cause hydrogen embrittlement.
- 2 Warm-bending should be carried out within the temperature range of 75°C to 100°C.

Hot-bending should be carried out within the temperature range of either 580°C to 630°C or 870°C to 920°C.

TABLE C1

RECOMMENDED MINIMUM FORMER DIAMETER FOR COLD-BENDING OF ROUNDS DURING FABRICATION

Diameter of bar (<i>d</i>) mm	Diameter of former mm			
	Grade			
	250	300	350	400
≤36	3 <i>d</i>	3 <i>d</i>	4 <i>d</i>	Warm-bend 4 <i>d</i>
>36 ≤50	4 <i>d</i>	4 <i>d</i>	Warm-bend 5 <i>d</i>	Hot-bend

TABLE C2

RECOMMENDED MINIMUM FORMER DIAMETER FOR COLD-BENDING OF FLATS AND SQUARES DURING FABRICATION

Thickness of bar (<i>t</i>) mm	Diameter of former mm			
	Grade			
	250	300	350	400
≤10	2 <i>t</i>	2 <i>t</i>	3 <i>t</i>	4 <i>t</i>
>10 ≤25	3 <i>t</i>	3 <i>t</i>	4 <i>t</i>	Warm-bend 4 <i>t</i>
>25 ≤50	4 <i>t</i>	5 <i>t</i>	Warm-bend 5 <i>t</i>	Hot-bend

NOTE: Bars should only be bent in the transverse direction.

APPENDIX D
SECTION DESIGNATIONS DIMENSIONS AND MASSES
(Normative)

This Appendix provides lists of common hot-rolled structural sections produced in Australia and New Zealand. The lists provide their section designation respective nominal dimensions and mass. These nominal values shall be used to calculate their section properties.

Figures D1 to D7 are not restrictive or exhaustive. Other sizes and shapes with different designations dimensions and masses may be produced to this Standard. Manufacturers shall provide the designation dimensions and mass for bars and sections produced that are not listed in Figures D1 to D7.

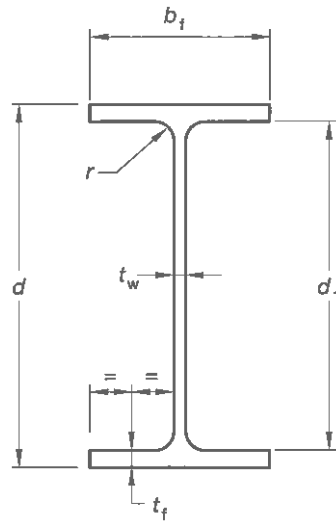

1 Designation kg/m	2 Depth of section (d) mm	3 Flange		5 Web thickness (t_w) mm	6 Root radius (r) mm	7 Depth between flanges (d_1) mm
		4 Width (b_f) mm	4 Thickness (t_f) mm			
610 UB 125	611.6	229.0	19.6	11.9	14.0	572.4
113	607.0	228.0	17.3	11.2	14.0	572.4
101	602.0	228.0	14.8	10.6	14.0	572.4
530 UB 92.4	533.0	209.0	15.6	10.2	14.0	501.8
82.0	528.2	209.0	13.2	9.6	14.0	501.8
460 UB 82.1	460.4	191.0	16.1	9.9	11.4	428.4
74.6	457.4	190.0	14.5	9.1	11.4	428.4
67.1	453.8	190.0	12.7	8.5	11.4	428.4
410 UB 59.7	406.4	178.0	12.8	7.8	11.4	380.8
53.7	402.6	178.0	10.9	7.6	11.4	380.8
360 UB 56.7	358.6	172.0	13.0	8.0	11.4	332.6
50.7	355.6	171.0	11.5	7.3	11.4	332.6
44.7	352.0	171.0	9.7	6.9	11.4	332.6
310 UB 46.2	307.2	166.0	11.8	6.7	11.4	283.6
40.4	304.0	165.0	10.2	6.1	11.4	283.6
32.0	298.0	149.0	8.0	5.5	11.4	282.0
250 UB 37.3	256.2	146.0	10.9	6.4	8.9	234.4
31.4	251.6	146.0	8.6	6.1	8.9	234.4
25.7	248.0	124.0	8.0	5.0	12.0	232.0
200 UB 29.8	207.0	134.0	9.6	6.3	8.9	187.6
25.4	203.2	133.0	7.8	5.8	8.9	187.6
22.3	201.6	133.0	7.0	5.0	8.9	187.6
18.2	198.0	99.0	7.0	4.5	11.0	184.0
180 UB 22.2	178.8	90.0	10.0	6.0	8.9	159.0
18.1	175.0	90.0	8.0	5.0	8.9	159.0
16.1	173.0	90.0	7.0	4.5	8.9	159.0
150 UB 18.0	155.0	75.0	9.5	6.0	8.0	136.0
14.0	150.0	75.0	7.0	5.0	8.0	136.0

FIGURE D1 UNIVERSAL BEAMS

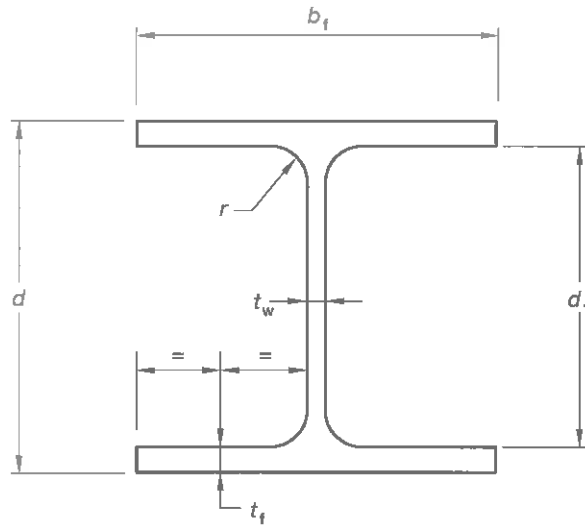

1	2	3	4	5	6	7	
Designation	Depth of section (d) mm	Flange		Web thickness (t_w) mm	Root radius (r) mm	Depth between flanges (d_1) mm	
		Width (b_f) mm	Thickness (t_f) mm				
kg/m							
310 UC	158	327.2	311.0	25.0	15.7	16.5	277.2
	137	320.6	309.0	21.7	13.8	16.5	277.2
	118	314.6	307.0	18.7	11.9	16.5	277.2
	96.8	308.0	305.0	15.4	9.9	16.5	277.2
250 UC	89.5	260.0	256.0	17.3	10.5	14.0	225.4
	72.9	253.8	254.0	14.2	8.6	14.0	225.4
200 UC	59.5	209.8	205.0	14.2	9.3	11.4	181.4
	52.2	206.4	204.0	12.5	8.0	11.4	181.4
	46.2	203.4	203.0	11.0	7.3	11.4	181.4
150 UC	37.2	161.8	154.0	11.5	8.1	8.9	138.8
	30.0	157.6	153.0	9.4	6.6	8.9	138.8
	23.4	152.4	152.0	6.8	6.1	8.9	138.8
100 UC	14.8	97.0	99.0	7.0	5.0	10.0	83.0

FIGURE D2 UNIVERSAL COLUMNS

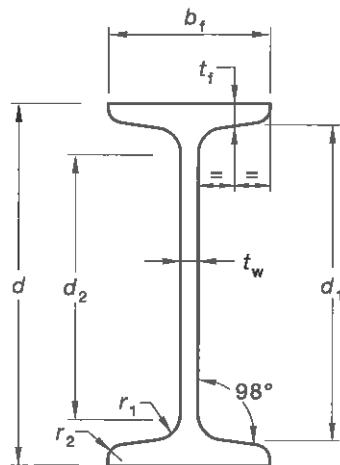

1	2	3	4	5	6	7	8	9	10
Designation	Mass per unit length kg/m	Depth of section (d) mm	Flange		Web thickness (t _w) mm	Depth at mid-point of flanges (d ₁) mm	Depth between fillets (d ₂) mm	Radii	
			Width (b _f) mm	Thickness (t _f) mm				Root (r ₁) mm	Toe (r ₂) mm
125 TFB	13.1	125.0	65.0	8.5	5.0	108	90	8.0	4.0
100 TFB	7.20	100.0	45.0	6.0	4.0	88	73	7.0	3.0

FIGURE D3 TAPERED-FLANGE BEAMS

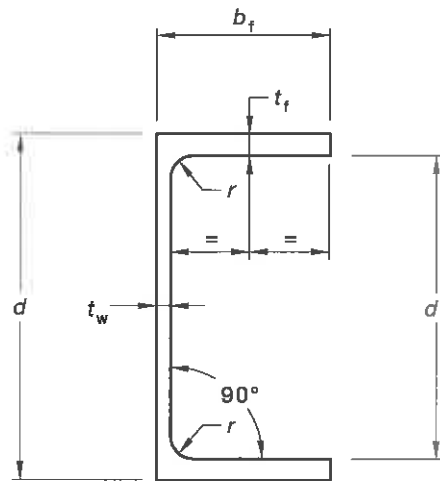

1	2	3	4		5	6	7	8
Designation	Mass per unit length kg/m	Depth of section (d) mm	Flange		Web thickness (tw) mm	Depth between flanges (d1) mm	Root radius (r) mm	
			Width (bf) mm	Thickness (tf) mm				
380 PFC	55.2	380.0	100.0	17.5	10.0	345.0	14.0	
300 PFC	40.1	300.0	90.0	16.0	8.0	268.0	14.0	
250 PFC	35.5	250.0	90.0	15.0	8.0	220.0	12.0	
230 PFC	25.1	230.0	75.0	12.0	6.5	206.0	12.0	
200 PFC	22.9	200.0	75.0	12.0	6.0	176.0	12.0	
180 PFC	20.9	180.0	75.0	11.0	6.0	158.0	12.0	
150 PFC	17.7	150.0	75.0	9.5	6.0	131.0	10.0	
125 PFC	11.9	125.0	65.0	7.5	4.7	110.0	8.0	
100 PFC	8.31	100.0	50.0	6.7	4.2	86.6	8.0	
75 PFC	5.90	75.0	40.0	6.1	3.8	62.8	8.0	

FIGURE D4 PARALLEL-FLANGE CHANNELS

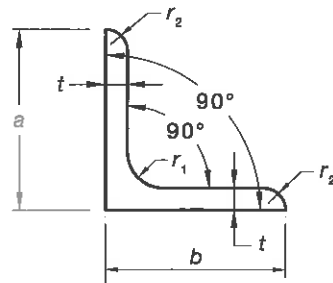

1	2	3	4	5		6
Designation		Mass per unit length	Actual thickness (t)	Radii		
Nominal leg size ($a \times b$) mm \times mm	Nominal thickness mm			Root (r_1) mm	Toe (r_2) mm	
200 \times 200	26	76.8	26.0	18.0	5.0	
	20	60.1	20.0	18.0	5.0	
	18	54.4	18.0	18.0	5.0	
	16	48.7	16.0	18.0	5.0	
150 \times 150	13	40.0	13.0	18.0	5.0	
	19	42.1	19.0	13.0	5.0	
	16	35.4	15.8	13.0	5.0	
	12	27.3	12.0	13.0	5.0	
125 \times 125	10	21.9	9.50	13.0	5.0	
	16	29.1	15.8	10.0	5.0	
	12	22.5	12.0	10.0	5.0	
	10	18.0	9.5	10.0	5.0	
100 \times 100	8	14.9	7.8	10.0	5.0	
	12	17.7	12.0	8.0	5.0	
	10	14.2	9.5	8.0	5.0	
	8	11.8	7.8	8.0	5.0	
90 \times 90	6	9.16	6.0	8.0	5.0	
	10	12.7	9.5	8.0	5.0	
	8	10.6	7.8	8.0	5.0	
	6	8.22	6.0	8.0	5.0	
75 \times 75	10	10.5	9.5	8.0	5.0	
	8	8.73	7.8	8.0	5.0	
	6	6.81	6.0	8.0	5.0	
	5	5.27	4.6	8.0	5.0	
65 \times 65	10	9.02	9.5	6.0	3.0	
	8	7.51	7.8	6.0	3.0	
	6	5.87	6.0	6.0	3.0	
	5	4.56	4.6	6.0	3.0	
55 \times 55	6	4.93	6.0	6.0	3.0	
	5	3.84	4.6	6.0	3.0	
	5	3.84	4.6	6.0	3.0	
	5	3.84	4.6	6.0	3.0	
50 \times 50	8	5.68	7.8	6.0	3.0	
	6	4.46	6.0	6.0	3.0	
	5	3.48	4.6	6.0	3.0	
	3	2.31	3.0	6.0	3.0	
45 \times 45	6	3.97	6.0	5.0	3.0	
	5	3.10	4.6	5.0	3.0	
	3	2.06	3.0	5.0	3.0	
	3	2.06	3.0	5.0	3.0	
40 \times 40	6	3.50	6.0	5.0	3.0	
	5	2.73	4.6	5.0	3.0	
	3	1.83	3.0	5.0	3.0	
	3	1.83	3.0	5.0	3.0	
30 \times 30	6	2.56	6.0	5.0	3.0	
	5	2.01	4.6	5.0	3.0	
	3	1.35	3.0	5.0	3.0	
	3	1.35	3.0	5.0	3.0	
25 \times 25	6	2.08	6.0	5.0	3.0	
	5	1.65	4.6	5.0	3.0	
	3	1.35	3.0	5.0	3.0	
	3	1.12	3.0	5.0	3.0	

NOTE: Column 2 shows the nominal thickness of the leg of the angle for designation only. The actual thickness is shown in Column 4.

(a) From Australian production

FIGURE D5 (in part) EQUAL ANGLES
COPYRIGHT

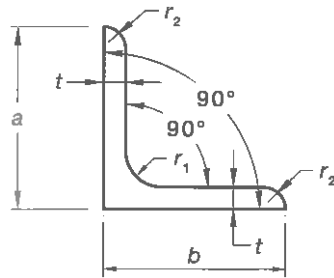

1	2	3	4	5	6
Designation		Mass per unit length kg/m	Actual thickness (t) mm	Radii	
Nominal leg size (a × b) mm × mm	Nominal thickness mm			Root (r ₁) mm	Toe (r ₂) mm
80 × 80	10	11.9	10.0	10.0	4.8
	8	9.63	8.0	10.0	4.8
	6	7.34	6.0	10.0	4.8
60 × 60	10	8.69	10.0	8.0	2.4
	8	7.09	8.0	8.0	2.4
	6	5.42	6.0	8.0	2.4
50 × 50	8	5.82	8.0	7.0	2.4
	6	4.47	6.0	7.0	2.4
	5	3.77	5.0	7.0	2.4
	3	2.33	3.0	7.0	2.4
40 × 40	5	2.97	5.0	6.0	2.4
	3	1.84	3.0	6.0	2.4
30 × 30	5	2.18	5.0	5.0	2.4
	3	1.36	3.0	5.0	2.4
25 × 25	5	1.77	5.0	3.5	2.4
	3	1.12	3.0	3.5	2.4

(b) From New Zealand production

FIGURE D5 (in part) EQUAL ANGLES

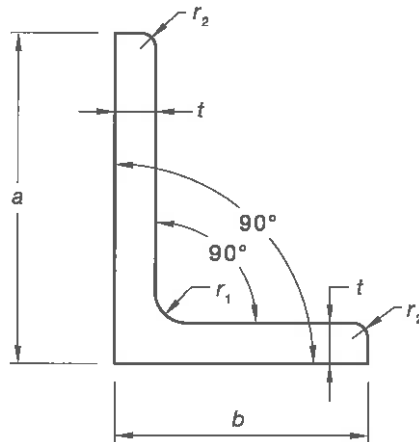

1	2	3	4	5	6
Designation		Mass per unit length	Actual thickness	Radii	
Nominal leg size ($a \times b$) mm \times mm	Nominal thickness mm			Root (r_1) mm	Toe (r_2) mm
150 \times 100	12	22.5	12.0	10.0	5.0
	10	18.0	9.5	10.0	5.0
150 \times 90	16	27.9	15.8	10.0	5.0
	12	21.6	12.0	10.0	5.0
	10	17.3	9.5	10.0	5.0
125 \times 75	8	14.3	7.8	10.0	5.0
	12	17.7	12.0	8.0	5.0
	10	14.2	9.5	8.0	5.0
100 \times 75	8	11.8	7.8	8.0	5.0
	6	9.16	6.0	8.0	5.0
	10	12.4	9.5	8.0	5.0
75 \times 50	8	10.3	7.8	8.0	5.0
	6	7.98	6.0	8.0	5.0
	8	7.23	7.8	7.0	3.0
65 \times 50	6	5.66	6.0	7.0	3.0
	5	4.40	4.6	7.0	3.0
	8	6.59	7.8	6.0	3.0
	6	5.16	6.0	6.0	3.0
	5	4.02	4.6	6.0	3.0

NOTE: Column 2 shows the nominal thickness of the leg of the angle for designation only. The actual thickness is shown in Column 4.

FIGURE D6 UNEQUAL ANGLES

APPENDIX E
 MEASUREMENT OF CAMBER AND SWEEP IN UNIVERSAL SECTIONS
 (Normative)

E1 GENERAL

Refer to Tables 7 and 8 for permissible variations in straightness.

E2 CAMBER

The length of section to be tested shall be placed with its web horizontal on a test surface. Camber is measured as shown in Figure E1.

E3 SWEEP

The length of section to be tested shall be placed with its web vertical on a test surface. Sweep is measured as shown in Figure E2.

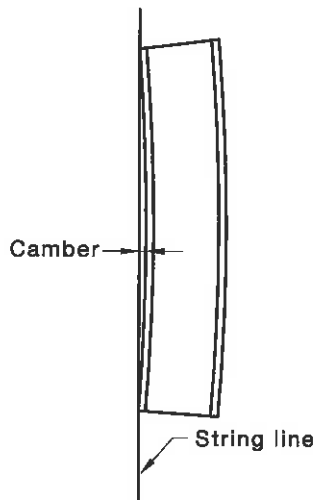

(a) Top view



(b) Section

FIGURE E1 CAMBER

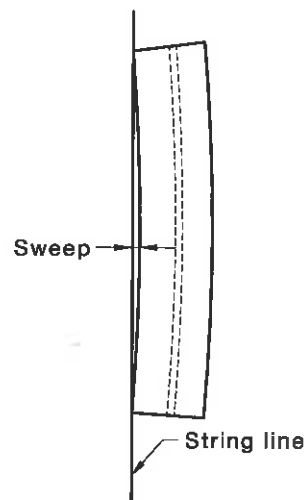

(a) Top view



(b) Section

FIGURE E2 SWEEP

APPENDIX F

STEEL FOR SEISMIC AND FRACTURE CRITICAL APPLICATIONS
(NEW ZEALAND ONLY)

(Normative)

F1 ADDITIONAL REQUIREMENTS FOR SEISMIC AND FRACTURE CRITICAL APPLICATIONS

Additional requirements for steel used for seismic and fracture critical applications are set out in NZS 3404.1. Where steel is required to be supplied for these applications, the steel shall comply with those additional requirements and as set out in this Appendix.

F2 STEEL FOR SEISMIC APPLICATIONS

The lower minimum yield stress R_{eL} shall be used for determining the limiting ratios in Table F1 for S0 grade seismic steels. The R_{eL} value used shall be either—

- (a) the R_{eL} value determined in accordance with AS 1391 and reported on the mill test certificate; or
- (b) the R_{eL} value calculated from the R_{eH} value reported on the mill test certificate using a probability of 0.05 for a confidence level of 0.75. These values shall be published by the manufacturer and made freely available to the purchaser on request.

TABLE F1

LIMITING RATIO REQUIREMENTS FOR S0 GRADE SEISMIC STEELS

Item	Requirements	Ratio
1	Maximum yield to tensile ratio (R_{eL}/R_m) (see Note 1)	0.8
2	Maximum yield stress R_{eL}	$<1.33f_y$ (see Note 2)
3	Maximum coefficient of variation for yield stress R_{eL}	$\leq 10\%$ (see Note 3)

NOTES:

- 1 The R_m value is the actual R_m value recorded on the mill test certificate.
- 2 f_y is the grade minimum yield stress from Table 14.
- 3 Coefficient of variation for the yield stress to be evaluated over a minimum period of 12 months.

F3 STEEL FOR FRACTURE CRITICAL MEMBERS

The following requirements apply:

- (a) Steel shall be manufactured using killed fine grain practice with continuous casting.
- (b) No weld repairs shall be performed to the steel.
- (c) The removal of defects from a section by grinding, or by chipping followed by grinding, shall not extend below the rolled surface by more than 0.5 mm for all thicknesses of material.
- (d) If heat numbers are to be applied by die stamping, low stress dies shall be used.

NOTE: Fracture critical members are typically fatigue sensitive members in bridges and other structures as defined in NZS 3404.1.

BIBLIOGRAPHY

AS

- 1171 Non-destructive testing—Magnetic particle testing for ferromagnetic products, components and structures
- 1199 Sampling procedures for inspection by attributes
- 1199.0 Part 0: Introduction to the ISO 2859 attribute sampling system
- 1199.1 Part 1: Sampling schemes indexed by acceptance quality limit (AQL) for lot-by-lot inspection
- 2062 Non-destructive testing—Penetrant testing of products and components
- 2490 Sampling procedures and charts for inspection by variables for percent nonconforming

AS/NZS

- 2312 Guide to the protection of structural steel against atmospheric corrosion by the use of protective coatings
- 2312.2 Part 2: Hot dip galvanizing

AS/NZS ISO

- 9001 Quality management systems—Requirements